

GATOR™ WORK SERIES

TRADITIONAL UTILITY VEHICLES



JOHN DEERE



GO TOUGH.
GO STRONG.

READY TO BRING IT

Pack more work in a day with the HPX615E and HPX815E models, equipped with our Deluxe Cargo Box. Composite construction makes it dent and rust resistant, while the flatbed mode makes it flexible on the job. A power lift kit, tool rack and side extension kit are available when you need to take it to the next level. Throw in 4WD and a 25 mph (40 km/h) top speed standard, and this Gator UV delivers on any terrain.

Check out the full Work Series lineup inside. You'll get more options, toughness, and grit to get the job done right.



These models feature Deluxe Cargo Box

	MID-SIZE				FULL-SIZE			
	TS	TE	TX	TX (CA)	TH Gas	TH Diesel	HPX615E (Gas)	HPX815E (Diesel)
HP	13.5 hp* (10.1 kW) (401cc)	48-volt system	15.5 hp* (11.6 kW) (675cc)	13.5 hp* (10.1 kW) (401cc)	15.5 hp* (11.6 kW) (675cc)	18.5 hp* (14 kW) (854cc)	21 hp* (16 kW) (617cc)	18.5 hp* (14 kW) (854cc)
Maximum Speed	20 mph (32 km/h)	15 mph (24 km/h)	20 mph (32 km/h)	20 mph (32 km/h)	20 mph (32 km/h)	20 mph (32 km/h)	25 mph (40 km/h)	25 mph (40 km/h)
Drive	4x2	4x2	4x2	4x2	6x4	6x4	4x4	4x4
Payload**/ Cargo Capacity	900 lb. (408 kg) / 500 lb. (227 kg)	900 lb. (363 kg) / 500 lb. (272 kg)	1,000 lb. (454 kg) / 600 lb. (273 kg)	1,000 lb. (454 kg) / 600 lb. (273 kg)	1,400 lb. (635 kg) / 1,000 lb. (454 kg)	1,600 lb. (726 kg) / 1,200 lb. (544 kg)	1,400 lb. (635 kg) / 1,000 lb. (590 kg)	1,400 lb. (635 kg) / 1,000 lb. (590 kg)

*@ 3600 RPM engine manufacturer certified gross power tested in accordance with SAE J1995. The engine horsepower and torque information are provided by the engine manufacturer to be used for comparison purposes only. Actual operating horsepower and torque will be less. Refer to the engine manufacturer's web site for additional information. **Includes 200-lb. operator and 200-lb. passenger and maximum box capacity.



12-volt DC outlets you'll find on most Gator UV's are similar to the ones used on boats and trucks.

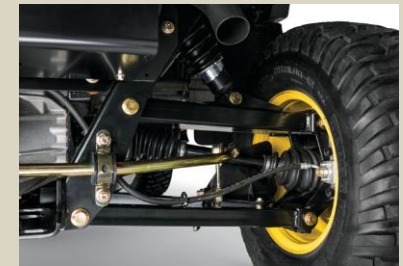

Every brake system is precisely matched to the vehicle load capacity. Stop with confidence.



Pick-up style tailgate folds out to 90 degrees, and down a full 150 degrees. Protect your investment with a factory-installed spray-on bedliner. Optional brake/tail light kit helps you stand out on the worksite. Twenty tie-down points let you secure cargo.



A standard gas assist shock underneath the bed makes lifting and dumping effortless. An optional power lift kit raises and lowers bed from a switch right on the dash.

FULL-SIZE

GO BIG.

THE HPX ADVANTAGE

This Gator is ready to work with its large payload and towing capacity, heavy-duty deluxe cargo box, and enhanced 4-wheel suspension. A top speed of 25 mph (40 km/h) helps you get the job done quickly, while the wide wheelbase and low center of gravity give you the stability you need when navigating rough terrain.

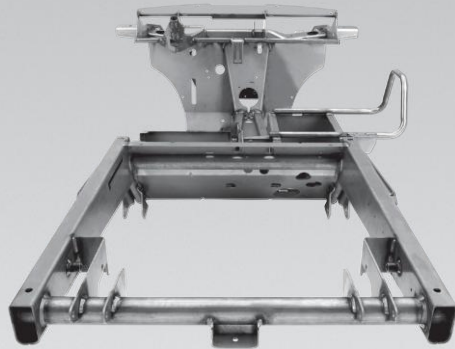

The hydroformed frame on the HPX has incredible tolerance for twisting and heavy loads.

Tailgate lights increase visibility for backing in dusk or low-light conditions.

The 2-in (5 cm) receiver hitch comes standard and offers added versatility when towing.

Wide wheelbase and low center of gravity keep the HPX grounded and stable.

The 4WD switch engages both front wheels with full torque, maximizing traction. The dual range CVT transmission helps tackle tough terrain too.



Sleeker styling paired with a heavy-duty front bumper for added protection.



Easy-to-dump cargo box with standard gas-assist or optional automatic power lift. The standard gas-assist shock makes dumping effortless, while the optional power lift kit easily raises and lowers the bed with the press of a button.



Built with tough, composite materials, this generous 16.4 cu. ft. (.56 cu. m.) cargo box can handle 1,000 lb. (450 kg) easy. And can help make light work of your work site.



Removable composite side panels and tailgate lets you quickly convert the cargo box to flatbed operation for carrying a variety of bulky objects. 20 integrated tie-down points help you easily secure any load.

Gas and Diesel engine options, producing 21 hp (16 kW) and 18.5 hp (14 kW) respectively offer power and performance.

Gator HPX615E (Gas) / HPX815E (Diesel) Specifications

ENGINE AND ELECTRICAL

Type	GAS 21 hp* (16 kW), Liquid-cooled, 2-cylinder, OHV, DIESEL 18.5 hp* (14 kW) Liquid-cooled, 3-cylinder, OHV,
Displacement	GAS 617 cc DIESEL 854 cc
RPM, idle fast (no load)	GAS 1125 +/- 75 3750 +/- 75 DIESEL 1050 +/- 50 3650 +/- 50
Maximum torque	GAS 32 ft.-lb. (44.4) @ 2500 rpm (Nm), DIESEL 33 ft.-lb. (45) @ 3350 rpm (Nm)

TRANSMISSION

Type	Continuously variable transmission (CVT)
Maximum Speed	0-25 mph (0-40 km/h forward, 0-12 mph (0-19 km/h) reverse

TRANSMISSION

System Type	On-demand true four-wheel drive system
Front Differential (Engagement)	Auto-locking (on/off rocker switch)
Rear Differential (Engagement)	Positive locking, mechanically actuated (hand-operated)
Gear Selection	Forward (hi-lo), Neutral, Reverse

SUSPENSION AND STEERING

Suspension, front	Independent with McPherson Strut
Front Susp. Travel (total)	5.15 in. (131 mm)
Suspension, rear	Coil over shock
Rear Susp. Travel (total)	3.5 in. (90 mm)
Turning radius	11 ft. (3.35 m)

BRAKES

Front/rear hydraulic disk	Front/rear hydraulic disk
---------------------------	---------------------------

Park brake	Rear mechanical disk, hand operated
------------	-------------------------------------

TIRES

Front	24x9.50-10
Rear	
Turf & AT489	24x12-10
All Trail II	24x10.50-10

FUEL SYSTEM

Capacity	5.3 U.S. gal./hr (20.1 l)
----------	---------------------------

GROUND CLEARANCE	6 in. (152 mm)
-------------------------	----------------

Under Foot Platform	12 in. (305 mm)
---------------------	-----------------

CARGO BOX

Material	Polypropylene side panels and tailgate, steel floor and load guard
----------	--

Capacity	1000 lb. (454 kg)
----------	-------------------

Dimensions, in. (mm)	45L x 52W x 11 D (1143L x 1320W x 304D)
----------------------	---

Volume	16.4 cu. ft. (.46 cu. m)
--------	--------------------------

Dump	Manual [power lift option]
------	----------------------------

Tailgate	Hinged at bottom, removable
----------	-----------------------------

Weight, lb. (Incl fuel, fluids)	HPX615E 1554 lb. (705 kg) HPX815E 1580 lb. (717 kg)
---------------------------------	---

DIMENSIONS

Height (overall with OPS)	73.5 in. (1867 mm)
---------------------------	--------------------

Width	58.5 in. (1486.5 mm)
-------	----------------------

Length with bumper	119 in. (3022 mm)
--------------------	-------------------

Wheelbase	75.2 in. (1910 mm)
-----------	--------------------

PAYLOAD/TOWING CAPACITY	1300 lb. (590 kg)
--------------------------------	-------------------

SEATING TYPE	2, Professional high back, bucket (tilt forward)
---------------------	--

OCCUPANT PROTECTIVE SYSTEM (OPS)	
---	--

Seat belts	3-point seat belts
------------	--------------------

Certification	SAE J2194 & OSHA ROPS & FOPS standard
---------------	---------------------------------------

GROUND PRESSURE (MAX)	14 psi (0.98 kg/cm2)
------------------------------	----------------------

Fully Loaded Vehicle	
----------------------	--

*@ 3600 RPM engine manufacturer certified gross power tested in accordance with SAE J1995. The engine horsepower and torque information are provided by the engine manufacturer to be used for comparison purposes only. Actual operating horsepower and torque will be less. Refer to the engine manufacturer's web site for additional information.

FULL-SIZE



FULL SIZE GATOR TH 6X4 **THE HEAVY DUTY CLASSIC**

With more power, more capacity and a whole lot more wheels on the ground, the gas and diesel Gator TH 6x4 models have a rock-solid-rep for digging in and moving mountains. And they're unbelievably stable—thanks to their extra-long wheelbase and low center of gravity. Plus, like the TX model, they include the high-capacity, convertible Deluxe Cargo Box. And they're light on turf. In short, when it comes to work, they bring it.

POPULAR OPTIONS:

- Heavy-duty bumper and brush guard
- Deluxe cab
- Cargo box power lift kit
- Blades/sprayers

ALSO INCLUDED:

- 12-Volt DC outlet
- Long-lasting wet disc
- Brakes made for stopping with heavy loads.
- Glove box
- Independent front suspension





High Performance bed sprayer provides an excellent way to apply materials such as liquid fertilizers, herbicides and de-icer. Cover ground quickly with flexible boom options: a 150" precision folding, 120" Standard 3 tip, 30' boomless, or no boom at all. (Boom sold separately.)

Six-wheel design offers excellent traction, while remaining turf friendly. Includes standard traction assist.

Take your pick of a gas or diesel engine. The diesel offers increased torque, excellent low-end lugging power and delivers more towing capacity as compared to its gas engine counterpart.



16.4 (.46 cu. m) cubic foot capacity reinforced box includes a gas-assist shock for easier lifting and dumping, pick-up style tailgate, 20 integrated tie-down points, and removable composite side panels and tailgate for flatbed operation. Also available: A factory-installed spray-on bedliner.

GATOR TH 6X4 GAS & DIESEL Specifications

ENGINE AND ELECTRICAL

Type	GAS 15.5 hp* (11.6 kW) air-cooled, overhead valves, 2-cylinder, 4-cycle DIESEL 18.5 hp (14 kW) Liquid-cooled, overhead-valves, 3-cylinder, 4-cycle
Displacement	GAS 675 cc (41.2 cu. in.) DIESEL 854 cc (52.1 cu. in.)
RPM, idle fast (no load)	GAS 1125 +/- 75 3850 +/-75 DIESEL 1050 +/- 50 13650 +/-75
Maximum torque	GAS 37.0 lb.-ft @ 2400 rpm DIESEL 34.6 lb.-ft @ 2400 rpm

TRANSMISSION

Type	Continuously variable transmission (CVT)
Maximum Speed	0-20 mph (0-32 km/h) forward, 0-19.4 mph (0-31.4 km/h) reverse
Differential Lock	Standard, hand-operated
Transaxle	Fully enclosed, oil bath
Gear Selection	Forward, reverse, neutral

SUSPENSION AND STEERING

Front	Independent spring over shock, single A-arm
Total travel	5 in. (127 mm)
Rear	Two high-flotation, low pressure tires (solid axles)
Steering	Rack and pinion
Turning radius	GAS 12.3 ft. (3.75 m) DIESEL 12.4 ft. (3.8 m)

BRAKES

Park brake	Wet disk, hand operated
------------	-------------------------

TIRES

Front	Two 22.5x10.00-8, 2 PR hi-flotation
Rear	Four 25x12.00-9, 2 PR hi-flotation

FUEL SYSTEM

Capacity	GAS 5 U.S. gal. (18.9 l) DIESEL 5.3 U.S. gal. (20 l)
----------	--

CARGO BOX

Material	Polypropylene side panels and tailgate, steel floor and load guard
Electric lift	Optional
Capacity	GAS 1000 lb. (454 kg) DIESEL 1200 lb. (544 kg)
Depth	12 in. (304.8 mm) / 45 in. (1143 mm)
Length	16.4 cu. ft. (0.46 cu. m)
Volume	52 in. (1320 mm) inside
Width	25 in. (635 mm)
Height above ground	Hinged at bottom, removable / side panels are removable
Tailgate	Hinged at bottom, removable

WEIGHT, LB. (Incl fuel, fluids)	GAS 1087 lb. (493 kg) DIESEL 1389 lb. (630 kg)
--	--

SEATING TYPE	2, Professional High Back
---------------------	---------------------------

Seat adjustment	Optional, driver's side
-----------------	-------------------------

DIMENSIONS

Height	43.6 in. (1108 mm)
Width	60 in. (1525 mm)
Length with/without bumper	108.4 in. (2754 mm) 105.9 in. (2689 mm)
Ground clearance,	
under foot platform	GAS 9.8 in. (250 mm) DIESEL 8.5 in. (216 mm)
under transaxle	GAS 6.7 in. (170 mm) DIESEL 6.5 in. (165 mm)
Wheelbase	79 in. (2006 mm) front to rear, 26.8 in. (680 mm) mid to rear

PAYLOAD/TOWING CAPACITY	GAS 1400 lb. (635 kg) DIESEL 1600 lb. (726 kg)
--------------------------------	--

GROUND PRESSURE (W 200 Lb. Operator Only)	6.9 psi (.49 kg/cm) front, 7.1 psi (.50 kg/cm) rear
---	---

*@ 3600 RPM engine manufacturer certified gross power tested in accordance with SAE J1995. The engine horsepower and torque information are provided by the engine manufacturer to be used for comparison purposes only. Actual operating horsepower and torque will be less. Refer to the engine manufacturer's web site for additional information.

MID-SIZE

GATOR TX TOP-OF-THE- LINE TWO- WHEEL DRIVE

Step up to the enhanced Gator TX from the TS and you'll appreciate the steep horsepower increase and the Deluxe Cargo Box. Whether you load it up or leave it empty, the TX delivers a well-cushioned ride with a specially tuned four-wheel suspension. Get one. And get the job done.

Available In California

POPULAR OPTIONS:

- Heavy-duty bumper and brush guard
- Deluxe cab
- Horn/light kits
- Cargo box power lift kit
- Blades/Sprayers
- Front receiver hitch

ALSO INCLUDED:

- High-Back Bucket Seats
- 12-Volt DC Outlet
- 4-Wheel Hydraulic Disk Brakes
- Rear Receiver Hitch



GO HEAVY.



Power under the hood delivers exceptional torque, great low-end lugging power and fast acceleration everywhere you go.



With a four-wheel suspension with coil over shock, triple-rate adjustable springs the TX offers a smooth ride no matter what you haul.



Composite sides can be removed in minutes, to convert the box to a flat-bed mode that's perfect for carrying large, awkward loads like plywood sheets, bales of hay, tables and more.



Cargo Box includes 16.4 cubic feet of capacity, pick-up style tailgate, 20 tie-down points, a gas-assist shock for easier lifting and dumping, and the ability to convert to a flat-bed mode in minutes.



Optional Box Side Extensions increase the amount of light material you can haul such as clippings and mulch when compared to a base model cargo box. Tailgate pivots at the top for ease of unloading loose material.



Easily repositioned Quick Clamp attachments like divider walls offer the ability to configure and reconfigure your cargo box in a few minutes with out tools.

GATOR TX 4X2 / TX 4X2 CALIFORNIA Specifications

ENGINE AND ELECTRICAL

Type	15.5 hp* (11.6 kW), Air-cooled / 13.5hp* (10.1kW), Air-cooled, overhead-valve 2-cylinder, 4-cycle gas /overhead-valve 1-cylinder, 4-cycle gas
Displacement	675 cc (41.2 cu. in.) / 401 cc, (24.5 cu. in.)
RPM, idle fast (no load)	1125 +/-75 3850 +/-75 / 1125 +/- 75 3750 +/- 75
Maximum torque	37.0 lb.-ft. @ 2400 rpm / 19.5 lb.-ft. @ 2400 rpm

TRANSMISSION

Type	Continuously variable transmission (CVT)
Maximum Speed	0-20 mph (0-32 km/h) forward, 0-19.4 mph (0-31.2 km/h) reverse
Differential Lock	Standard; hand-operated
Transaxle	Fully enclosed; oil bath
Gear Selection	Forward, neutral, reverse

SUSPENSION AND STEERING

Front	Independent spring over shock, single A-arm
Total travel	5 in. (127 mm)
Rear	Semi Independent Adjustable Coil over Shock
Total travel	3 in. (76.2 mm)
Steering	Rack and pinion
Turning radius	12 ft. (3.65 m)

BRAKES

All-wheel hydraulic disc	
--------------------------	--

Park brake	Rear mechanical disc, hand operated
------------	-------------------------------------

TIRES

Front	Two 22x9.50-10, 4 PR,
Rear	Two 24x10.50-10 HPAP, 24x12-10 Turf/Hard Surface & HPAT

FUEL SYSTEM

Capacity	5 U.S. gal. (18.9 l)
----------	----------------------

CARGO BOX

Material	Polypropylene side panels and tailgate, steel floor and load guard
Electric lift	Optional
Capacity	600 lb. (272 kg)
Depth	12 in. (304.8 mm)
Length	45 in. (1143 mm)
Volume	16.4 cu. ft. (0.46 cu. m)
Width	52 in. (1320 mm) inside
Height above ground	30 in. (762 mm)
Tailgate	Hinged at bottom, removable; side panels are removable

WEIGHT, LB. (Incl fuel, fluids)	1120 lb. (508 kg)
---------------------------------	-------------------

SEATING TYPE

2, Professional High Back, tilt forward	
---	--

Seat adjustment	Optional, driver's side
-----------------	-------------------------

DIMENSIONS

Height	43.6 in. (1108 mm)
Width	60 in. (1525 mm)
Length with/without bumper	112.1 in. (2847 mm) / 109.6 in. (2788 mm)
Ground clearance,	
under foot platform	10.6 in. (270 mm)
under transaxle	5.7 in. (145 mm)
Wheelbase	72.5 in. (1841 mm)

PAYLOAD/TOWING CAPACITY	1000 lb. (454 kg)
-------------------------	-------------------

GROUND PRESSURE (W 200 Lb. Operator Only)	6.2 psi (0.44 kg/cm ²) front, 11.6 psi (.82 kg/cm ²) rear
--	---

*@ 3600 RPM engine manufacturer certified gross power tested in accordance with SAE J1995. The engine horsepower and torque information are provided by the engine manufacturer to be used for comparison purposes only. Actual operating horsepower and torque will be less. Refer to the engine manufacturer's web site for additional information.

MID-SIZE

GATOR TS GO WITH THE BASICS.



Choose from a variety of cab options.

POPULAR OPTIONS:

- Heavy-Duty Bumper and Brush Guard
- Horn/Light Kits
- Utility Carts
- Power Lift Kit
- Rear Receiver Hitch

The affordable Gator TS offers an amazing capacity for cargo, combined with a surprisingly light footprint on turf (only 7.5 psi – less than a human foot). It's powered by a 401cc gas engine, comes complete with classic mid-back bucket seats and a rugged cargo box in back. No wonder it's popular from the rental yard to the front yard.



GATOR TS 4x2 Specifications

ENGINE AND ELECTRICAL

Type	13.5hp* (10.1kW), Air-cooled, overhead-valve, 1-cylinder, 4-cycle gas
Displacement	401 cc, (24.5 cu. in.)
RPM, idle fast (no load)	1125 +/-75 3750 +/-75
Maximum torque	19.5 lb.-ft. @ 2400 rpm

TRANSMISSION

Type	Continuously variable transmission (CVT)
Maximum Speed	0-20 mph (0-32 km/h) forward, 0-19.4 mph (0-31.2 km/h) reverse
Differential Lock	Standard; hand-operated
Transaxle	Fully enclosed; oil bath
Gear Selection	Forward, neutral, reverse

SUSPENSION AND STEERING

Front	Independent spring over shock, single A-arm
Total travel	5 in. (127 mm)
Rear	Two high-flotation, low pressure tires (solid axles)
Steering	Rack and pinion
Turning radius	11.25 ft. (3.5 m)

BRAKES

Park brake	Wet disk, hand operated
------------	-------------------------

TIRES

Front	Two 22.5x10.00-8, 2 PR hi-flotation
Rear	Two 25x12.00-9, 2 PR hi-flotation

FUEL SYSTEM

Capacity	5.2 U.S. gal. (19.7 l)
----------	------------------------

CARGO BOX

Material	16 gauge steel
Electric lift	Optional
Capacity	500 lb. (227 kg)
Depth	9 in. (229 mm)
Length	39.5 in. (1003 mm)
Volume	10.1 cu. ft. (0.29 cu. m)
Width	49 in. (1245 mm)
Height above ground	25 in. (635 mm)
Tailgate	Hinged at bottom, removable
Weight, lb. (Incl fuel, fluids)	915 lb. (415 kg)

SEATING TYPE

Seat adjustment	2, Standard medium back, tilt forward
Optional driver's seat	

DIMENSIONS

Front tread centers	50.0 in. (1270 mm)
Height	43.6 in. (1108 mm)
Width	60 in. (1525 mm)
Length with/without bumper	104.0 in. (2746 mm) / 101.4 in. (2576 mm)
Ground clearance,	
under foot platform	9.8 in. (250 mm)
under transaxle	6.0 in. (152.4 mm)
Rear Tread Centers	48 in. (1220 mm)
Wheelbase	69.7 in. (1770 mm)

PAYLOAD/TOWING CAPACITY

	900 lb. (408 kg)
--	------------------

GROUND PRESSURE

	5.6 psi (0.39 kg/cm ²) front, 7.5 psi (0.53 kg/cm ²) rear
--	---

(W 200 Lb. Operator Only)

*@ 3600 RPM engine manufacturer certified gross power tested in accordance with SAE J1195. The engine horsepower and torque information are provided by the engine manufacturer to be used for comparison purposes only. Actual operating horsepower and torque will be less. Refer to the engine manufacturer's web site for additional information.

GATOR TE GO ELECTRIC

There's never been a better time to make the switch to an all-electric utility vehicle. The Gator TE can run all day on a single overnight charge*, and haul up to 500-lb. (227 kg) with the same Deluxe Cargo Box you'll find on the TX and TH. All while giving you the advantage of zero emissions and zero fuel consumption. Plus it's so quiet, you won't believe your ears. Comes standard with a UL-approved charger that automatically shuts off after reaching full charge.

POPULAR OPTIONS:

- Heavy-duty front bumper & brushguard
- Deluxe cab
- Cargo box power lift kit

16.4 cubic foot (.46 cu. m) capacity reinforced box includes a gas assist for easier lifting and dumping, pick-up style tailgate, 20 integrated tie-down points, and removable side panels and tailgate for flatbed operation.

The 48-volt electrical system provides power to perform evenly all day long¹.



GATOR TE Specifications

DRIVE SYSTEM

Motor	6.0 hp (4.6 kW) separately excited D.C. motor (30 minute S2 rating)
Controller	Separately excited, 400 current limit
Transaxle	16.99:1 ratio with helical gearing
Electrical System	48 volt system
Maximum Speed	0-15 mph (24.1 km/h)
Gear Selection	Forward, Neutral, Reverse
Battery	Trojan T-105
Extended Run Time Battery	Trojan T-145

BRAKES

Type	Dual rear wheel mechanical drum, auto adjust
Park Brake	Hand operated, multi-latch

TIRES

Front	22.5x10.00-8, 4-ply hi-flotation turf
Rear	25x12.00-9, 4-ply hi-flotation turf

SUSPENSION AND STEERING

Front	Independent, spring over shock, single A-Arm
Total Travel	5 in. (127 mm)
Rear	2 hi-flotation, low pressure tires
Steering	Rack and pinion

DIMENSIONS

Height – in. (mm)	44.5 in. (1130 mm)
Width – in. (mm)	60 in. (1524 mm)
Length – in. (mm)	–
With / Without Bumper	107.4 in. (2728 mm) / 104.9 in. (2664 mm)
Ground Clearance	7.3 in. (185 mm) under Foot Platform
Wheelbase	69.7 in. (1770 mm)
Vehicle Weight	1302 lb. (627 kg) w/batteries / T145: 1470 lb. (667 kg)
Turning Clearance Circle	24.1 ft. (7.3 m)

PAYLOAD/TOWING CAPACITY

	900 lb. (409 kg) / 600 lb. (273 kg)
--	-------------------------------------

SEATS

Type	2 Professional high back bucket, tilt forward
Seat Adjustment	Optional

CARGO BOX

Material	Polypropylene side panels and tailgate steel floor and load guard
Length	45 in. (1143 mm)
Width	52 in. (1320 mm) inside
Depth	12 in. (304.8 mm)
Capacity	500 lb. (227 kg)
Volume	16.4 cu. ft. (0.46 cu. m3)
Height Above Ground	25 in. (635 mm)
Tailgate	Hinged at bottom, removable / side panels are removable
Dump	Manual (optional power lift)

GROUND PRESSURE

(With 200 lb. operator only)	8.6 psi (fully loaded)
------------------------------	------------------------

CHARGER

Type	Ferroresonant transformer
Input Voltage	120V AC +/- 10% input, 60 HZ
Input Current	12 amps AC (at start)
True RMS Power	1200 Watts
Estimated Full Recharge Time	12 hours TE105 / 16 hours TE145

¹Based on typical usage of the average commercial operator for an 8 hour work day.

GO GATOR.



JOHN DEERE

This literature has been compiled for worldwide circulation. While general information, pictures and descriptions are provided, some illustrations and text may include finance, credit, insurance, product options and accessories NOT AVAILABLE in all regions. PLEASE CONTACT YOUR LOCAL DEALER FOR DETAILS. John Deere reserves the right to change specification, design and price of the products described in this literature without notice. John Deere's green and yellow color scheme, the leaping deer symbol, and JOHN DEERE are trademarks of Deere & Company.



DSTA73830 (18-06)

www.JohnDeere.com/Gator

www.JohnDeere.ca/Gator